

Polypipe Building Products Ltd

Broomhouse Lane
Edlington
Doncaster
South Yorkshire DN12 1ES
Tel: 01709 770000 Fax: 01709 770001
e-mail: enquiries@polypipe.com
website: www.polypipe.com/bp



Agrément Certificate
00/3699
Product Sheet 3

POLYPIPE PLUMBING SYSTEMS

POLYPIPE FLOOR HEATING SYSTEMS – UNDER FLOOR, OVERLAY AND MODULAR HEATING PANELS

PRODUCT SCOPE AND SUMMARY OF CERTIFICATE

This Certificate relates to Polypipe Floor Heating Systems — Under Floor, Overlay and Modular Heating Panels, for use in plumbing services, in new and existing floors, with a source of heated water and appropriate components, to provide a space heating system in domestic, commercial and public buildings.

AGRÉMENT CERTIFICATION INCLUDES:

- factors relating to compliance with Building Regulations where applicable
- factors relating to additional non-regulatory information where applicable
- independently verified technical specification
- assessment criteria and technical investigations
- design considerations
- installation guidance
- regular surveillance of production
- formal three-yearly review.



KEY FACTORS ASSESSED

Safe working temperatures and pressures — the maximum working temperatures and pressures have been assessed (see section 6 of this Certificate).

Durability — the pipe and fittings have an equivalent service life to that of traditional metal pipe and fittings (see section 12 this Certificate).

The BBA has awarded this Agrément Certificate to the company named above for the systems described herein. These systems have been assessed by the BBA as being fit for their intended use provided they are installed, used and maintained as set out in this Certificate.

On behalf of the British Board of Agrément

Date of First issue: 18 June 2010

Originally certified on 29 March 2000

Handwritten signature of Brian Chamberlain in black ink.

Brian Chamberlain

Head of Approvals — Engineering

Handwritten signature of Greg Cooper in black ink.

Greg Cooper

Chief Executive

The BBA is a UKAS accredited certification body — Number 113. The schedule of the current scope of accreditation for product certification is available in pdf format via the UKAS link on the BBA website at www.bbacerts.co.uk

Readers are advised to check the validity and latest issue number of this Agrément Certificate by either referring to the BBA website or contacting the BBA direct.

British Board of Agrément
Bucknalls Lane
Garston, Watford
Herts WD25 9BA

©2010

tel: 01923 665300
fax: 01923 665301
e-mail: mail@bba.star.co.uk
website: www.bbacerts.co.uk

Regulations

In the opinion of the BBA, Polypipe Floor Heating Systems — Under Floor, Overlay and Modular Heating Panels, if used in accordance with the provisions of this Certificate, will meet or contribute to meeting the relevant requirements of the following Building Regulations:



The Building Regulations 2000 (as amended) (England and Wales)

Requirement:	L1(a)(ii)	Conservation of fuel and power
Comment:		Floor heating systems incorporating the products can satisfy this Requirement. See sections 5.1, 5.2, 5.4 and 5.5 of this Certificate.
Requirement:	B3(3)	Internal fire spread (structure)
Comment:		With suitable fire-stopping, pipes passing through an element of structure or cavity barriers will satisfy this Requirement. See section 9 of this Certificate.
Requirement:	Regulation 7	Materials and workmanship
Comment:		The systems are acceptable. See sections 12.1 to 12.3 and the <i>Installation</i> part of this Certificate.



The Building (Scotland) Regulations 2004 (as amended)

Regulation:	8(1)(2)	Fitness and durability of materials and workmanship
Comment:		The systems can contribute to a construction satisfying this Regulation. See sections 11.1 to 11.4 and 12.1 to 12.3 and the <i>Installation</i> part of this Certificate.
Regulation:	9	Building standards — construction
Standard:	2.2	Separation
Comment:		With suitable fire-stopping, pipes passing through an element of structure or cavity barriers will satisfy this Regulation, with reference to clause 2.2.9 ⁽¹⁾⁽²⁾ . See section 9 of this Certificate.
Standard:	3.13	Heating
Comment:		Floor heating systems incorporating the products can satisfy this Standard, with reference to clauses 3.13.1 ⁽¹⁾ and 3.13.2 ⁽¹⁾ . See sections 5.1, 5.2 and 5.5 of this Certificate.
Standard:	6.3	Heating system
Comment:		Floor heating systems incorporating the products can satisfy this Standard, with reference to clauses 6.3.1 ⁽¹⁾⁽²⁾ and 6.3.2 ⁽¹⁾⁽²⁾ . See sections 5.1, 5.2 and 5.5 of this Certificate.
Standard:	6.4	Insulation of pipes, ducts and vessels
Comment:		Floor heating systems incorporating the products can satisfy this Standard, with reference to clause 6.4.1 ⁽¹⁾⁽²⁾ . See sections 5.4 of this Certificate. (1) Technical Handbook (Domestic). (2) Technical Handbook (Non-Domestic).



The Building Regulations (Northern Ireland) 2000 (as amended)

Regulation:	B2	Fitness of materials and workmanship
Comment:		The systems are acceptable. See sections 12.1 to 12.3 and the <i>Installation</i> part of this Certificate.
Regulation:	B3(2)	Suitability of certain materials
Comment:		The systems are acceptable. See sections 11.1 to 11.4 of this Certificate.
Regulation:	E4	Internal fire spread — Structure
Comment:		With suitable fire-stopping, pipes passing through an element of structure or cavity barriers will satisfy this Regulation. See section 9 of this Certificate.
Regulation:	F2(a)(ii)	Conservation measures
Comment:		Floor heating systems incorporating the products can satisfy this Regulation. See sections 5.1, 5.2, 5.4 and 5.5 of this Certificate.
Regulation:	F3(a)(ii)	Target carbon dioxide emission
Comment:		Floor heating systems incorporating the products can satisfy this Regulation. See section 5.5 of this Certificate.

Construction (Design and Management) Regulations 2007

Construction (Design and Management) Regulations (Northern Ireland) 2007

In the opinion of the BBA, there is no information in this Certificate which relates to the obligations of the client, CDM co-ordinator, designer and contractors under these Regulations.

Water Supply (Water Fittings) Regulations 1999 England and Wales, Water Byelaws 2000, Scotland, and the Water Regulations, Northern Ireland

England and Wales

In the opinion of the BBA, Polypipe Floor Heating Systems — Under Floor, Overlay and Modular Heating Panels satisfy the requirements of the Regulations, if used and installed in accordance with this Certificate.

Scotland

In the opinion of the BBA, Polypipe Floor Heating Systems — Under Floor, Overlay and Modular Heating Panels satisfy the requirements of the Water Byelaws, if used and installed in accordance with this Certificate.

Northern Ireland

In the opinion of the BBA, Polypipe Floor Heating Systems — Under Floor, Overlay and Modular Heating Panels satisfy the requirements of the Water Regulations, if used and installed in accordance with this Certificate.

Non-regulatory Information

NHBC Standards 2010

NHBC accepts the use of Polypipe Floor Heating Systems — Under Floor, Overlay and Modular Heating Panels when installed and used in accordance with this Certificate, in relation to *NHBC Standards*, Chapter 8.1 *Internal services*, clauses D14 and D15 *Space heating*.

General

This Certificate relates to Polypipe Floor Heating Systems — Under Floor, Overlay and Modular Heating Panels, for use in domestic plumbing services, in new and existing floors, with a source of heated water and appropriate components, to provide a space heating system in domestic and commercial buildings.

The Polypipe Under Floor Heating System (UFCH) can be applied to:

- solid, insulated concrete floors — the pipe is buried within the screed
- floating floors — the pipe is laid in insulation panels and covered by chipboard
- suspended floors — the pipe is laid in insulated panels fitted between joists and covered with normal floorboards.

The Polypipe Overlay⁽¹⁾ Heating System is available in two types to suit the coverings and is applied over existing floors.

The Polypipe Modular Heating Panels (MHP) incorporate the pipe and are fitted between joists (timber or engineered) and connected together on site.

A Zonal Regulation Unit (ZRU) is used to control the system in single rooms or extensions up to 30 m² in area and the standard Polypipe heating manifolds (see Figure 2) are used in multiple room installations.

This Certificate does not cover the boiler, existing pumps and controls necessary to complete the heating system, which are assumed to be conventional items.

(1) Overlay is a registered trademark.

Technical Specification

1 Description

1.1 The three types of Polypipe Floor Heating System are:

- Polypipe Under Floor Heating System (using 15 mm, 18 mm and 20 mm diameter barrier pipes) — for use in solid, floating and suspended floors
- Polypipe Overlay Floor Heating System (using 10 mm or 12 mm diameter barrier pipes) — for use over existing floors
- Polypipe Modular Heating Panels (MHP) (using 10 mm diameter barrier pipes) — for use between joists in suspended floors with traditional or engineered joists.

Polypipe Underfloor Heating System

1.2 The Polypipe 15 mm, 18 mm and 20 mm Under Floor Heating System comprises:

- Polypipe Polyplumb PB barrier pipe — a polybutylene (PB) barrier pipe of 15 mm, 18 mm or 20 mm nominal diameter with wall thicknesses of 1.7 mm, 2.0 mm and 2.0 mm respectively, made up of five co-extruded layers: an inner and outer layer of PB and a central oxygen diffusion barrier of ethylene vinyl alcohol (EVOH) copolymer bounded on either side by an adhesive bonding layer (see Figure 1).

Figure 1 Polyplumb barrier pipe

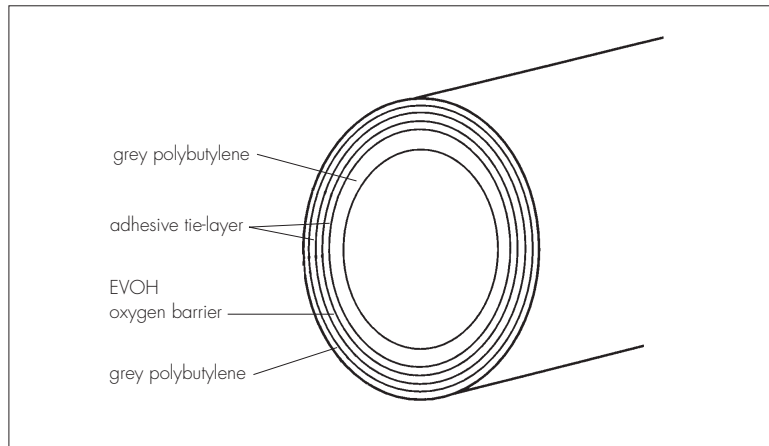

- Polypipe manifold — cast from dezincification-resistant brass and mounted on galvanized brackets. The manifold options are available in a range from two- to twelve-port connections, and couplings are used for joining the pipe to the manifold (see Figure 2). For the 15 mm pipe a Polyplumb push-fit fitting to BS 7291-2 : 2010 is used; for the 18 mm and 20 mm pipes compression fittings are used. The length of pipe from the manifold to the exit from the floor is protected using Polypipe corrugated conduit. The manifolds are vital to the system as they control the flow of heated water through the underfloor pipe circuits.

Figure 2 Typical manifold



- Polyplumb pipe stiffeners — made of polysulphone or stainless steel and inserted in each pipe end for use when joining pipe with push-fit and compression fittings.

1.3 Ancillary items used with the system⁽¹⁾ are:

- Polypipe heat spreader plates
- Polypipe floor panels
- Polypipe corrugated conduit
- Polypipe edge strips
- standard UFCH⁽²⁾ pipe clips
- floating floor panels
- UFCH⁽²⁾ valve actuators
- isolation valves
- UFCH⁽²⁾ mixing valves
- single room control unit.

(1) These items were outside the scope of the original assessment.

(2) Polypipe's abbreviation for Under Floor Central Heating.

Manufacture

1.4 The polybutylene pipe is produced by an extrusion process; the polybutylene layers, adhesive tie layers and oxygen diffusion barrier layer are co-extruded. Continuous quality control is carried out during manufacture, including checks on dimensional accuracy, and short-term pressure tests at 20°C and 95°C.

1.5 Manifolds and brass components are manufactured using conventional techniques and bought-in by the Certificate holder, to an agreed specification.

Polypipe Overlay Floor Heating System

1.6 The Polypipe Overlay Floor Heating System comprises:

- Polypipe Polyplumb PB barrier pipe — a grey polybutylene (PB) barrier pipe of 10 mm and 12 mm nominal diameter of the same construction as for the 15 mm to 20 mm diameter Polyplumb barrier pipe (see Figure 1).
- Overlay Floor Panels (see Figure 3) — available in two types to suit either heavyweight (Overlay) or lightweight (Overlay Lite) floor coverings:
 - Overlay — manufactured from light-grey, cellulose-fibre-reinforced, gypsum, fire-resistant, 18 mm thick fibreboard in two sizes (400 mm and 800 mm long by 600 mm wide) with a density of 1180 kg·m⁻³. Each panel has four grooves at 150 mm centres formed along its length to suit the Polyplumb pipe diameter
 - Overlay Lite — manufactured from blue, extruded polystyrene (PS-X) of a high compressive strength; lightweight insulated panel covered by a self-adhesive aluminium foil; in one size of 1245 mm by 600 mm by 18 mm thick, with four grooves at 150 mm centres formed along its length to suit the Polyplumb pipe diameter
- End Return Panels (see Figure 3) — manufactured from polypropylene (PP) with matching grooves in the floor panels at 150 mm centres. Available in two sizes: — 300 mm by 133 mm for 10 mm pipe — 300 mm by 144 mm for 12 mm pipe
- Polyurethane Expanding Foam Adhesive — used to fix together adjacent Overlay Floor Panels and End Return Panels
- Jointing Staples, type 80, 14 mm — used to fix together adjacent Overlay Floor Panels and End Return Panels
- Adaptor Sets — manufactured from brass or engineering plastic and reduce the diameter from 15 mm to suit 12 mm or 10 mm pipe. Each set is supplied with pipe stiffeners which must be inserted into the pipe end before jointing
- Zonal Regulation Unit (ZRU) — allows single rooms and extensions (up to 30 m²) to be connected to an existing radiator heating system. It controls the water flow and temperature to suit the underfloor heating system and can also be used with conventional underfloor heating systems employing 15 mm diameter polybutylene pipe in single rooms with an area up to 30 m²
- Aluminium foil — self-adhesive foil, 50 mm wide, used to secure joints between Overlay Lite panels and to secure the pipes in the Overlay Lite panels.

Figure 3 Overlay Floor and End Return Panels

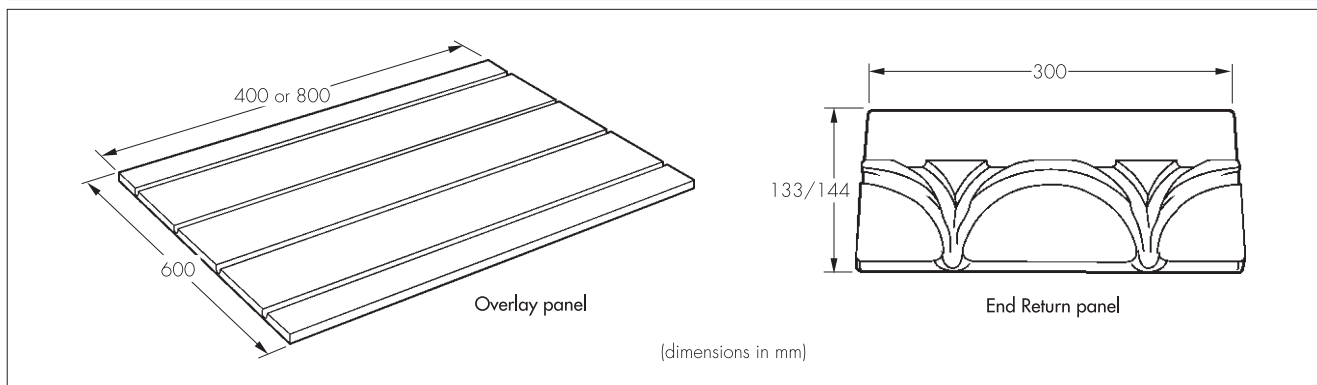

1.7 Ancillary items that can be used with the system are:

- Manifold (see Figure 2) — used where more than one room is fitted with the system and is available with a standard 18 mm diameter connection and from two to twelve ports. The manifold is supplied with mounting brackets, drain cock and air bleed, and push-fit ends for pipe connection.
- Isolation Valve — 25 mm diameter, available to connect the manifold unit to both the UFCH control pack and the modulating pump unit
- Mixing Valve — available in two sizes: 22 mm and 28 mm
- The UFCH control pack — comprises a pump, two-port motorised valve, mixer valve and isolation valve in one unit
- The Modulating Pump Unit — comprises a modulating pump, mixer valve and thermometer in one unit.

Polypipe Modular Heating Panel

1.8 Polypipe Modular Heating Panels consist of insulation panels incorporating grooves to accommodate the barrier pipe fitted in the factory. To enable connection, two pipes in each panel extend by 500 mm from one end. A layer of foil is bonded to the top surface of the panel entrapping the pipe. The panels are available in different sizes to suit joist spacing (see Table 1) and can be used in combination to suit floor spans. The components comprise:

- Polypipe Polyplumb PB barrier pipe — a grey polybutylene (PB) barrier pipe of 10 mm nominal diameter of the same construction as for the 12 mm to 20 mm diameter Polyplumb barrier pipe (see Figure 1).
- Insulation panels (see Figure 4) — manufactured from lightweight white expanded polystyrene (EPS) with grooves formed in the upper surface to receive the pipe and their position indicated by embossed markings on the underside to help avoid fixing screws being put through the pipe
- Heat diffusion foil — self-adhesive aluminium foil bonded over the pipe

- Zonal Regulation Unit (ZRU) — allows single rooms and extensions (up to 30 m²) to be connected to an existing radiator heating system. The ZRU controls the water flow and temperature to suit the underfloor heating system. The ZRU can also be used with conventional underfloor heating systems employing 15 mm diameter polybutylene pipe in single rooms with an area up to 30 m².

Table 1 MHP dimensions

Length (mm)	Width (mm)	Thickness (mm)
1332 and 2000	490	30
1332 and 2000	380	30
1332 and 2000	330	30

Figure 4 Polypipe Modular Heating Panel System — Typical installation

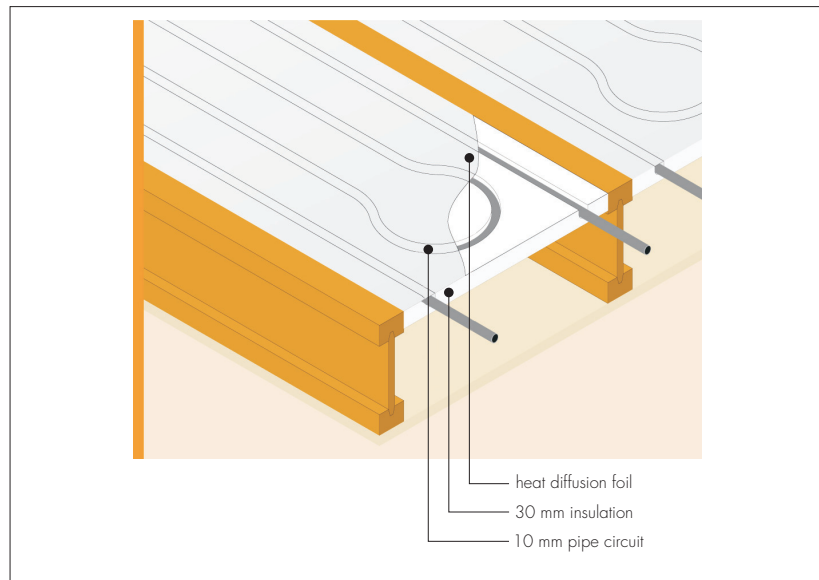

1.9 Ancillary items for use with the system are:

- Manifold (see Figure 2) — used where more than one room is fitted with the system and is available with a standard 15 mm diameter connection and from two to twelve ports. The manifold is supplied with mounting brackets, drain cock and air bleed, and push-fit ends for pipe connection.
- Mixing Valve — available in two sizes, 22 mm and 28 mm
- The UFCH control pack — comprises a pump, two-port motorised valve, mixer valve and isolation valve in one unit
- Alpha UFH Control pack — comprises a modulating pump, mixer valve and thermometer in one unit
- Isolation Valve — 25 mm diameter, available to connect the manifold unit to both the UFCH control pack and the modulating pump unit.

2 Delivery and site handling

Barrier pipe

2.1 Barrier pipe is supplied in straight lengths of 3 m or 6 m or in coils of 25 m, 50 m, 100 m, 150 m or 200 m. The pipe bears a continuous marking showing the manufacturer's trademark, maximum operating temperature and pressure and time, day, month and year of production. The pipes are also marked with the legend BARRIER in red at regular intervals and the number of this Certificate. They are wrapped in yellow packaging carrying a label bearing the legend BARRIER PIPE.

2.2 The pipe should be transported on a flat-bed vehicle and straight pipes arranged to avoid any overhang or crushing.

2.3 Once unwrapped, pipes should be stored indoors or in a shaded area to prevent ultraviolet degradation; to prevent distortion, pipes should be stored in racks which give support to the whole length.

Fittings

2.4 Fittings are supplied in polyethylene bags.

2.5 Manifolds, distribution boxes and other small components are supplied in cardboard packaging.

2.6 The Modular Heating Panels are delivered in packs of five sealed in polyethylene bags. The pipe connections are protected by cardboard and the panels taped together at the other end. All modular panels should be stored under cover until required, to prevent exposure to ultraviolet light and site damage.

2.7 Overlay panels are delivered on pallets of 10 or 30 panels and Overlay Lite panels in polyethylene bags of 10 or 20 panels.

Assessment and Technical Investigations

The following is a summary of the assessment and technical investigations carried out on Polypipe Floor Heating Systems — Under Floor, Overlay and Modular Heating Panels.

Design Considerations

3 General

- 3.1 The Polypipe Under Floor Heating System is suitable for use in domestic, commercial and public buildings under concrete, suspended and floating floors.
- 3.2 The Polypipe Overlay Floor Heating System is suitable for use in domestic, commercial and public buildings, and can be installed in new or existing buildings over concrete and timber floors.
- 3.3 The Polypipe Modular Heating System is suitable for use in domestic, commercial and public buildings, and can be installed in new or existing buildings from above or below the floor joists.
- 3.4 The Certificate holder's technical literature contains data essential to the designer.
- 3.5 Walls and ground-supported sub-floors of existing buildings must incorporate suitable damp-proof courses and membranes to prevent ground moisture reaching the inside of the building. Where a concrete sub-floor does not already incorporate suitable damp-proofing, a polyethylene membrane of 250 micron thickness should be laid over the sub-floor.
- 3.6 Each system is controlled by either a manifold and a modulating pump unit (for multi-room installations) or a ZRU (for single rooms with an area up to 30 m²).
- 3.7 Care must be taken during installation to ensure that damage does not occur to the pipe, eg by nail or screw penetration.

4 Practicability of installation

The systems are designed to be installed by a competent builder, or contractor, experienced with these types of system.

5 Design procedure



5.1 The procedures for system design are based on heat loss per room. The design methodology for each of the installation methods is given in the Certificate holder's *Technical Installation Guide*, TIG 1, July 2009.

5.2 The heating demands for particular rooms are evaluated in the manner detailed in the CIBSE Guide *A Environmental Design, 2006, Part A Structural Design*, BS EN 1264-2 : 2008, BS EN 1264-3 : 2009 and BS EN 1264-4 : 2009.

5.3 For the calculations to determine the pressure drop in the pipes connected to each radiator, the total length of pipe is defined as the sum of the length of the flow and return pipes from the boiler to the radiator.



5.4 Pipes used for the supply of domestic hot water and heating pipes that pass through areas not contributing to space heating must be insulated in accordance with the requirements of the relevant national Building Regulations.

5.5 Floor constructions must be designed to comply with the relevant technical specifications selected from:

- BS EN 1992-1-1 : 2004
- BS EN 1995-1-1 : 2004
- the national Building Regulations:
 - England and Wales** — Approved Document A 1/2, Section 1, Part B, and Approved Document L1(a)
 - Scotland** — Mandatory Standard 1.1(a)(b), clauses 1.1.1⁽¹⁾⁽²⁾ and 1.1.3⁽¹⁾⁽²⁾ and Mandatory Standard 3.1.3
 - (1) Technical Handbook (Domestic).
 - (2) Technical Handbook (Non-Domestic).
 - Northern Ireland** — Technical Booklets F2 and F3.

6 Safe working temperatures and pressures

6.1 The safe operating pressure and maximum temperature rating for Polyplumb PB barrier pipe is 4.0 bar at 60°C and 7 bar at 82°C. The pipe can operate at 3.5 bar at 114°C for a limited period without damage. There is an adequate safety factor to ensure that damage to the pipe is unlikely to occur in the event of boiler thermostat or other control failure.

6.2 The maximum permissible operating temperature of the Overlay system is 50°C. This temperature is maintained at the inlet to the manifolds, or in the ZRU, by a mixing valve set at 50°C.

6.3 The ZRU supplements the water flow which ensures that the Polypipe Overlay Floor Heating System is not reliant on the pump pressure from the existing heating system. Water is thermostatically blended by the unit to provide a safe

flow of temperature-controlled water around the Overlay Panel piping. Sensors ensure that the unit only operates when heated water is available from the existing heating system.

7 Chemical resistance

7.1 The polybutylene of the barrier pipe will be unaffected by soft, hard or aggressive potable water.

7.2 The material used in Polyplumb PB Barrier Pipe and Fittings could be adversely affected by contact with some types of soldering flux and associated sealing compounds⁽¹⁾, and should not come into contact with these materials.

(1) These traditional components are not used with the products.

8 Effect on water quality

The Polyplumb PB barrier pipe and fittings are listed by the Water Regulations Advisory Scheme.

9 Properties in relation to fire



Where the Polyplumb PB barrier pipe passes through an element of structure or cavity barrier the opening should be fire-stopped in a way that will permit thermal movement.

10 Flow characteristics

10.1 The bore of the 10 mm, 12 mm, 15 mm, 18 mm and 20 mm diameter barrier pipe is less than copper or stainless steel pipe of the same outside diameter. The consequent reduction in flow rate for a given pressure head should be considered when designing hot and cold water distribution or central heating systems.

10.2 The insertion of pipe stiffener sleeves into the pipe does not affect the flow characteristics.

11 Maintenance



11.1 The systems assessed do not require special maintenance. Items such as the control equipment are outside the scope of this Certificate but may require routine maintenance.

11.2 The EVOH barrier in the barrier pipe virtually eliminates the diffusion of oxygen into the heating system provided the system is completely sealed. The checking and addition of a corrosion inhibitor is recommended on a yearly basis.

11.3 All peripheral items, ZRU and control equipment may be replaced easily.

11.4 If the heat output from the system reduces during its lifetime, it may be necessary to periodically flush the pipework to remove any residue that may have formed.

12 Durability



12.1 The Polyplumb PB barrier pipe material has been assessed as having a life in excess of 50 years. The manifold is produced from materials known to be durable in plumbing applications. It may require replacement within the life of the pipe.

12.2 The Polypipe Overlay Floor Heating System is made from durable materials that have a life at least equivalent to that expected from a traditional installation with pipes and fittings, when incorporated in correctly designed systems.

12.3 The manifolds, ZRU, mixer valves and other components of the system are constructed from materials known to be durable in plumbing applications.

Installation

13 Under Floor Heating System

Installation of the Polypipe 15 mm, 18 mm and 20 mm Under Floor Heating System must be carried out in accordance with the manufacturer's instructions and BS 6700 : 2006. General installation details are shown in Figure 1.

14 Procedure

14.1 The procedures are detailed in the Certificate holder's *Technical Installation Guide*, TIG 1, July 2009. A summary is given in sections 14.2 to 14.7.

Solid concrete floor (see Figure 6)

Figure 6 Polypipe Underfloor Heating System — Typical screed–solid floor installation

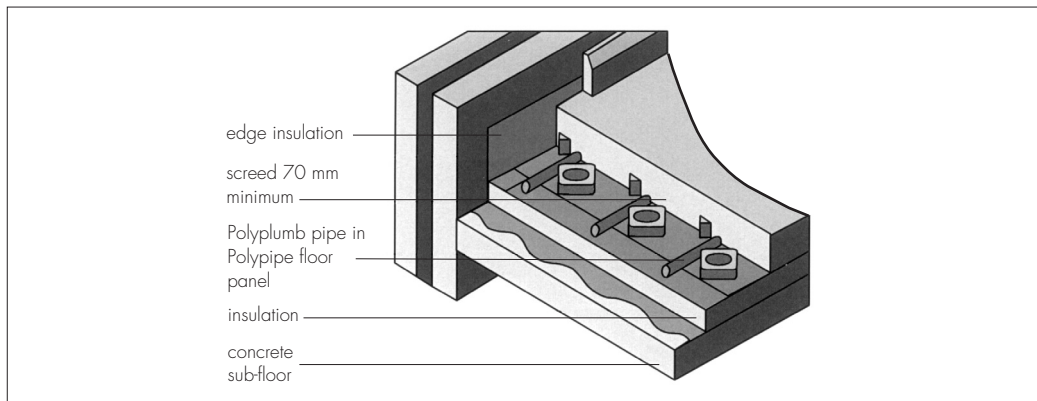

14.2 Polypipe edge strip is positioned around the perimeter of the room. Expanded polystyrene is laid onto the concrete sub-base and covered with a polyethylene membrane. Polypipe floor panels are recommended to secure the Polyplumb PB barrier pipe in standard installations.

14.3 The system should be pressure tested before the concrete screed or cement–sand is laid over the pipe. Should pressure testing take place in sub-zero temperatures, or if the system is to be left after pressure testing in sub-zero temperatures, all necessary precautions should be taken to avoid frost damage to the pipework. The thickness of the screed will be dependent upon the loading requirements of the floor, but the cover to the pipe must not be less than 40 mm. The screed should be laid in accordance with the relevant requirements of BS 8204-1 : 2003.

Suspended wooden floor (see Figure 7)

Figure 7 Polypipe Underfloor Heating System — Typical suspended wooden floor installation

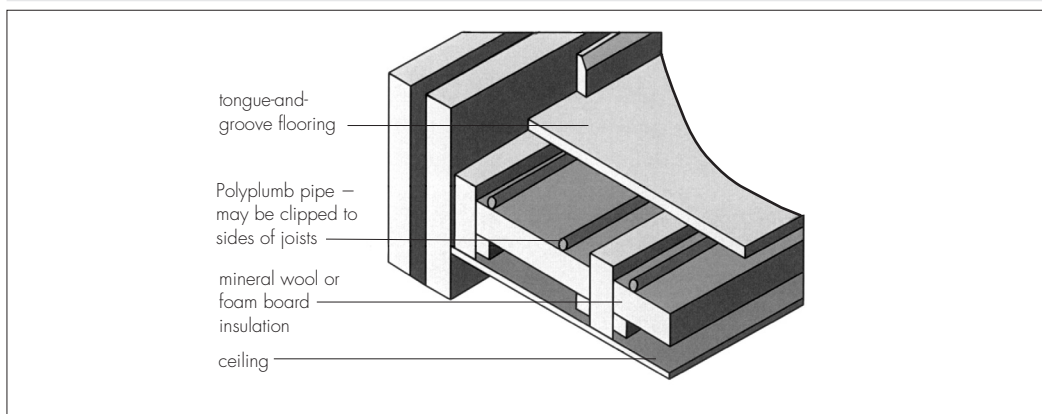

14.4 The system can be used in suspended floors with installation conducted from either over the top or bottom of the suspended floor. The pipework can be clipped to the joists or run in heat spreader plates along counter battens fitted at 300 mm centres. The voids between the joists should be filled with an appropriate mineral wool or foam insulation. Some carpentry will be necessary to fit this system. Structural timbers should be notched only with the permission of the architect or structural engineer, and in accordance with BS 6700 : 2006. The system should be pressure tested before nailing down the floor deck (see Figure 7).

Floating floor (see Figure 8)

Figure 8 Polypipe Under Floor Heating System — Typical floating floor installation

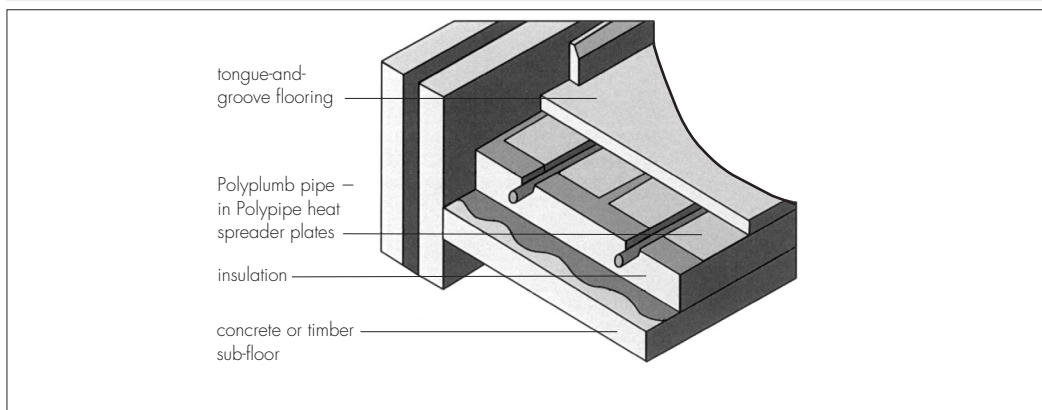

14.5 The floating floor insulation panels are laid on top of the existing floor. A polyethylene membrane must be used if required by the type of installation. The heat spreader plates are positioned on the insulation and the Polyplumb PB barrier pipe is rolled out over the floor in a zigzag configuration. The system can be connected and pressurised as detailed in the Certificate holder's instructions.

Charging and pressure testing

14.6 Prior to screeding or concealing, the system must be flushed with water so that all the heating circuits are free from air. This is carried out circuit by circuit (ie with the valves for the other circuits remaining closed). When all air is bled from the pipe and manifolds, the system can be pressure tested. The system should be tested to 6.0 bar, but may require five or six applications of the pressure to achieve stability, as the pipe will expand slightly as it is pressurised. The pressure must remain stable for a minimum of 24 hours before the system has settled and is functioning satisfactorily. Special precautions are necessary if the pressure testing is to take place in sub-zero temperatures.

Commissioning

14.7 Heat must not be applied until any screed has fully dried. Advice should be sought from the screed supplier for the drying times.

15 Overlay systems

15.1 Installation of the Polypipe Overlay and Overlay Lite Floor Heating System must be carried out in accordance with the manufacturer's Installation instructions and BS 6700 : 2006. General installation details are shown in Figure 9.

Figure 9 Typical Overlay installation

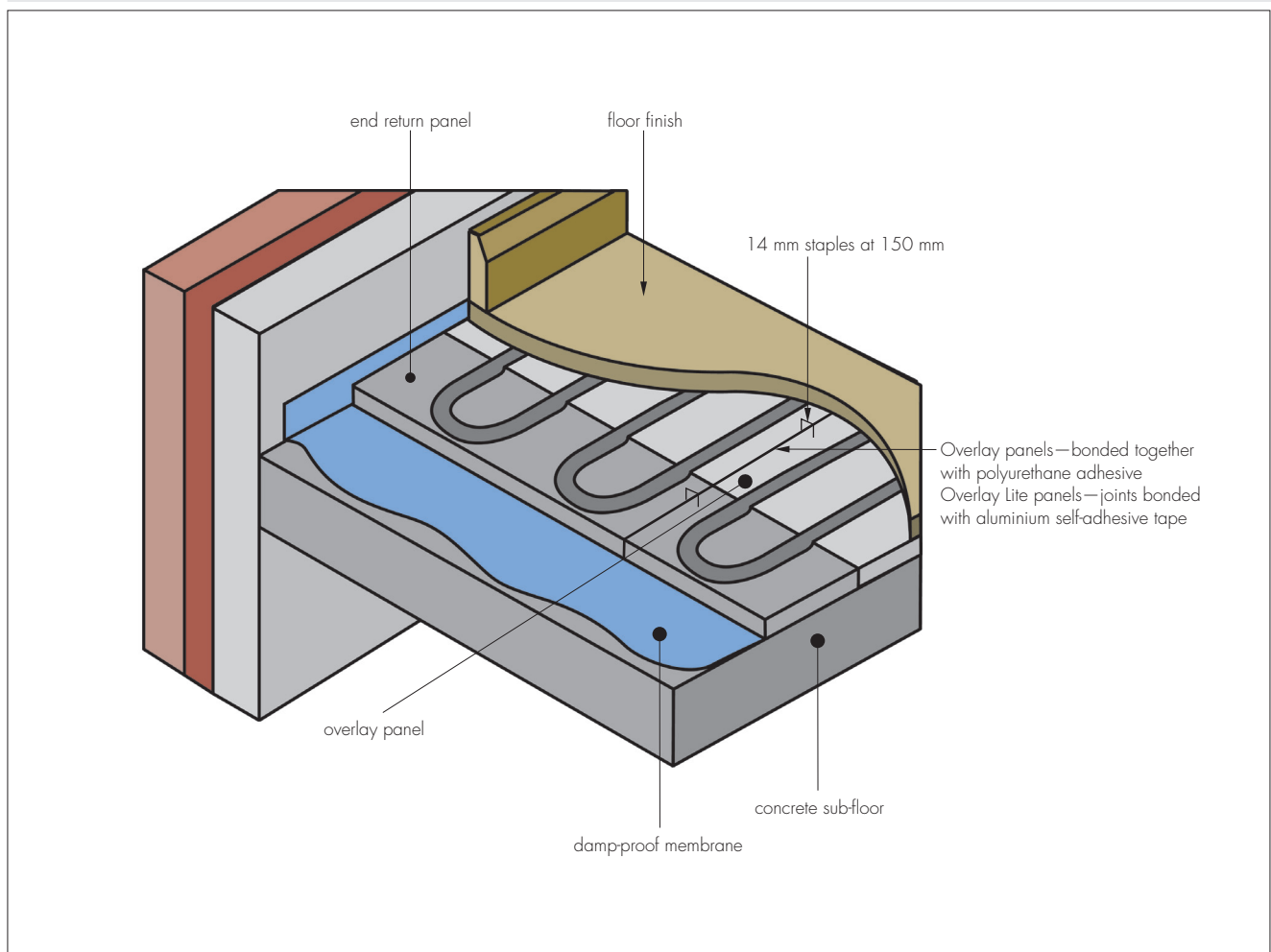

15.2 The installation of the system must be carried out on a level, clean and dry surface, using a self-levelling compound to fill any minor dips. During installation, self-levelling granules can also be brushed in to fill any minor dips under the panels. All skirting boards should be removed before starting the installation.

15.3 Walls and ground-supported sub-floors must incorporate suitable damp-proof courses and membranes to prevent ground moisture reaching the inside of the building. Where a concrete sub-floor does not already incorporate suitable damp-proofing, a polyethylene membrane of 250 micron thickness should be laid over the sub-floor, allowing a 75 mm overlap at the sides and edges, and fixed behind the skirting board. Care must be taken to ensure the dpm is not pierced during the entire installation.

15.4 During installation of Overlay panels, adequate ventilation to the room is required to avoid dust build-up when cutting panels.

16 Procedure

- 16.1 The orientation of the panels and pipe runs are made in the direction of the longest edge of the room with the return bends on the shortest walls. This will ensure the minimum required amount of return bends.
- 16.2 The first two return bend panels are placed at each end of the room.
- 16.3 Overlay panels are bonded together using an expanding polyurethane adhesive; a continuous bead of glue is applied to the end of the first panel and laid against the return bends, ensuring the bead is at the centre of the board and that the glue does not flow into the pipe grooves or on top of the board surface. Care must be taken that the corners of the overlay panels are not broken when moving and glueing. Overlay Lite panels are fixed together and to the End Return panels with the 48 mm wide aluminium self-adhesive tape as soon as they are laid, retaining the pipes beneath.
- 16.4 Overlay panels must be jointed within 10 minutes of applying the adhesive and must not be walked on for a further 10 to 15 minutes to ensure joints are not broken by movement whilst the adhesive sets. Adhesive should only be applied to the end of each panel prior to butting up the previous panel.
- 16.5 When the two return bends and the overlay panel are in place the joint is stapled using Type 80, 14 mm staples, every 150 mm across the joints between the panels. The staples should be central between the pipe grooves in the panels.
- 16.6 When nearing the end of the first run of Overlay panels, an allowance is made for the return bends and a panel is cut to size to complete the run, using a handsaw or an electric jigsaw set at a slow speed. To ensure the Overlay panels are correctly aligned with the End Return panels, four short pieces of Polyplumb pipe can be used across the joints of the panel grooves. Overlay Lite panels can be cut using a sharp knife and a straightedge.
- 16.7 Flow and return pipes are run at the sides/ends of rooms.
- 16.8 The panels are laid along the length of the room with staggered joints and the end returns along the wall as work proceeds backwards.
- 16.9 All dust and debris must be removed from the pipe grooves prior to fitting pipes into the panel grooves.
- 16.10 The pipe is inserted into the Overlay panels grooves and care taken to avoid kinking the pipes. If necessary, a soft-head mallet can be used to tap the pipes carefully into the grooves. Enough pipe should be allowed at the start and end of each circuit to connect to the ZRU or manifolds. With Overlay Lite panels, the pipes are inserted into the grooves and held in place with the aluminium foil tape across the ends of adjacent panels.
- 16.11 When the pipe is installed, the system can be connected to the ZRU, covering pipes entering and exiting the ZRU using the ZRU Pipe Shroud. The pipes are connected to the Polypipe ZRU (if used) using a 15 mm by 12 mm brass adaptor or a 15 mm by 10 mm PB adaptor. Multiple circuits can be accommodated by using 15 mm Polyplumb tees and elbows and manifolds. All normal installation procedures must be observed when installing Polyplumb pipes and fittings.
- 16.12 The system is filled and pressure tested in accordance with the *Technical Installation Guide*, TIG 1, July 2009.
- 16.13 The positioning of the ZRU and manifold (if appropriate) is determined by the most convenient location of heating supply. The final return is run along the short edge of the room back to the ZRU or manifold.
- 16.14 When the room floor dictates that more than one circuit is required, the system flow from the ZRU is taken to the furthest point, working back to the unit. This will ensure the furthest run is the warmest.

Finishing

- 16.15 Any excess adhesive can be removed with a chisel.
- 16.16 Tiles or wood/laminate floor can be applied directly over the Overlay system using staples, screws or adhesive ensuring not to pierce the pipes. Laminated and engineered wood can be laid directly over Overlay Lite panels; tiles must not be used with Overlay Lite panels.
- 16.17 It is recommended that a 6 mm thick waterproof plywood cover is installed over the Overlay panels and pipes when carpet is to be fitted as the floor finish. The plywood can be retained with staples or screws with Overlay panels, and with adhesive with Overlay Lite panels.
- 16.18 Once the floor covering has been applied, the skirting board can be fixed by floating above the finished floor.

17 Modular Heating Panels

- 17.1 Installation of the Polypipe Modular Heating Panel System must be carried out in accordance with the *Technical Installation Guide*, TIG 1, July 2009 and BS 6700 : 2006. General installation details are shown in Figure 4.
- 17.2 When installing the system from above, support bearers are fitted to each side of the joists at 30 mm from the top of the joist.
- 17.3 For installation of the system from below, the position of the panels must be marked to ensure that they are positioned correctly for heating the room above. The panels are slotted into place and fixed to the underside of the floor.

18 Procedure

18.1 The panels can be fixed to the underside of the floor using 1 3/4" x No 8 woodscrews with M6 x 30 mm diameter washers. It is advisable to use six fixings per panel ensuring that the moulded pipe marking on the underside of the panel is avoided.

18.2 Electrical cables must not be in physical contact with the MHP panels and should be isolated by using tape or polyethylene strip.

18.3 Flow and return pipes are run at the sides/ends of rooms or, where a set of panels is fitted either side of a room, the flow and return pipes are run between the sets.

18.4 Connections to the 10 mm diameter inlet and outlet pipes of each panel are made using standard Polyplumb fittings⁽¹⁾ following the normal installation procedures for these products.

(1) Fittings such as: 15 mm by 10 mm reduced tee branch, 15 mm by 10 mm reduced branch spigot tee, 15 mm by 10 mm socket reducer.

18.5 The system is filled and pressure tested in accordance with the *Technical Installation Guide*, TIG 1, July 2009.

Technical Investigations

19 Tests

19.1 Tests were carried out to determine the resistance to short-term pressure at 20°C and 95°C at elevated pressure.

19.2 Test evidence was examined relating to:

- dimensional accuracy
- effect of thermal cycling on pipes and fittings
- oxygen diffusion
- long-term hydrostatic pressure resistance of pipe⁽¹⁾
- short-term hydrostatic pressure resistance of fittings⁽¹⁾
- hydrostatic pressure resistance of manifolds
- pull-out resistance of manifold connections
- performance of the mixing valve
- thermal and flow performance of a system when controlled by a ZRU.

(1) To BS 7291-1 : 2006.

20 Other investigations

20.1 An examination was made of data relating to:

- heat output
- thermal stability of oxygen diffusion barrier
- behaviour in fire
- effect of materials on water quality
- chemical resistance
- practicability of installation
- suitability of the joints
- durability
- opacity.

20.2 The design and installation method was examined and compared to conventional practice in the UK.

20.3 The factory production control was examined and found to be in accordance with the guidance on quality control testing given in BS 7291-2 : 2006. The pipe and fittings are covered by BSI Kitemark

Bibliography

- BS 6700 : 2006 *Design, installation, testing and maintenance of services supplying water for domestic use within buildings and their curtilages — Specification*
- BS 7291-1 : 2006 *Thermoplastics pipes and associated fittings for hot and cold water for domestic purposes and heating installations in buildings — General requirements*
- BS 7291-2 : 2006 *Thermoplastics pipes and associated fittings for hot and cold water for domestic purposes and heating installations in buildings — Specification for polybutylene (PB) pipes and associated fittings*
- BS 7291-2 : 2010 *Thermoplastics pipe and fitting systems for hot and cold water for domestic purposes and heating installations in buildings — Specification for polybutylene (PB) pipe and associated fittings*
- BS 8204-1 : 2003 *Screeds, bases and in-situ floorings — Concrete bases and cement sand levelling screeds to receive floorings — Code of practice*
- BS EN 1264-2 : 2008 *Water based surface embedded heating and cooling systems — Floor heating — Prove methods for the determination of the thermal output using calculation and test methods*
- BS EN 1264-3 : 2009 *Water based surface embedded heating and cooling systems. Dimensioning*
- BS EN 1264-4 : 2009 *Water based surface embedded heating and cooling systems — Installation*
- BS EN 1992-1-1 : 2004 *Eurocode 2 : Design of concrete structures — General rules and rules for buildings*
- BS EN 1995-1-1 : 2004 *Eurocode 5 : Design of timber structures — General — Common rules and rules for buildings*
- NA to BS EN 1995-1-1 : 2004 *UK National Annex to Eurocode 5 : Design of timber structures — General — Common rules and rules for buildings*

21 Conditions

21.1 This Certificate:

- relates only to the product/system that is named and described on the front page
- is granted only to the company, firm or person named on the front page — no other company, firm or person may hold or claim any entitlement to this Certificate
- is valid only within the UK
- has to be read, considered and used as a whole document — it may be misleading and will be incomplete to be selective
- is copyright of the BBA
- is subject to English law.

21.2 Publications and documents referred to in this Certificate are those that the BBA deems to be relevant at the date of issue or re-issue of this Certificate and include any: Act of Parliament; Statutory Instrument; Directive; Regulation; British, European or International Standard; Code of Practice; manufacturers' instructions; or any other publication or document similar or related to the aforementioned.

21.3 This Certificate will remain valid for an unlimited period provided that the product/system and the manufacture and/or fabrication including all related and relevant processes thereof:

- are maintained at or above the levels which have been assessed and found to be satisfactory by the BBA
- continue to be checked as and when deemed appropriate by the BBA under arrangements that it will determine
- are reviewed by the BBA as and when it considers appropriate.

21.4 In granting this Certificate, the BBA is not responsible for:

- the presence or absence of any patent, intellectual property or similar rights subsisting in the product/system or any other product/system
- the right of the Certificate holder to manufacture, supply, install, maintain or market the product/system
- individual installations of the product/system, including the nature, design, methods and workmanship of or related to the installation
- the actual works in which the product/system is installed, used and maintained, including the nature, design, methods and workmanship of such works.

21.5 Any information relating to the manufacture, supply, installation, use and maintenance of this product/system which is contained or referred to in this Certificate is the minimum required to be met when the product/system is manufactured, supplied, installed, used and maintained. It does not purport in any way to restate the requirements of the Health & Safety at Work etc Act 1974, or of any other statutory, common law or other duty which may exist at the date of this Certificate; nor is conformity with such information to be taken as satisfying the requirements of the 1974 Act or of any statutory, common law or other duty of care. In granting this Certificate, the BBA does not accept responsibility to any person or body for any loss or damage, including personal injury, arising as a direct or indirect result of the manufacture, supply, installation, use and maintenance of this product/system.

Blank page

